

lightly

butterfly | wall-mount

installation guide for standalone and
continuous run applications

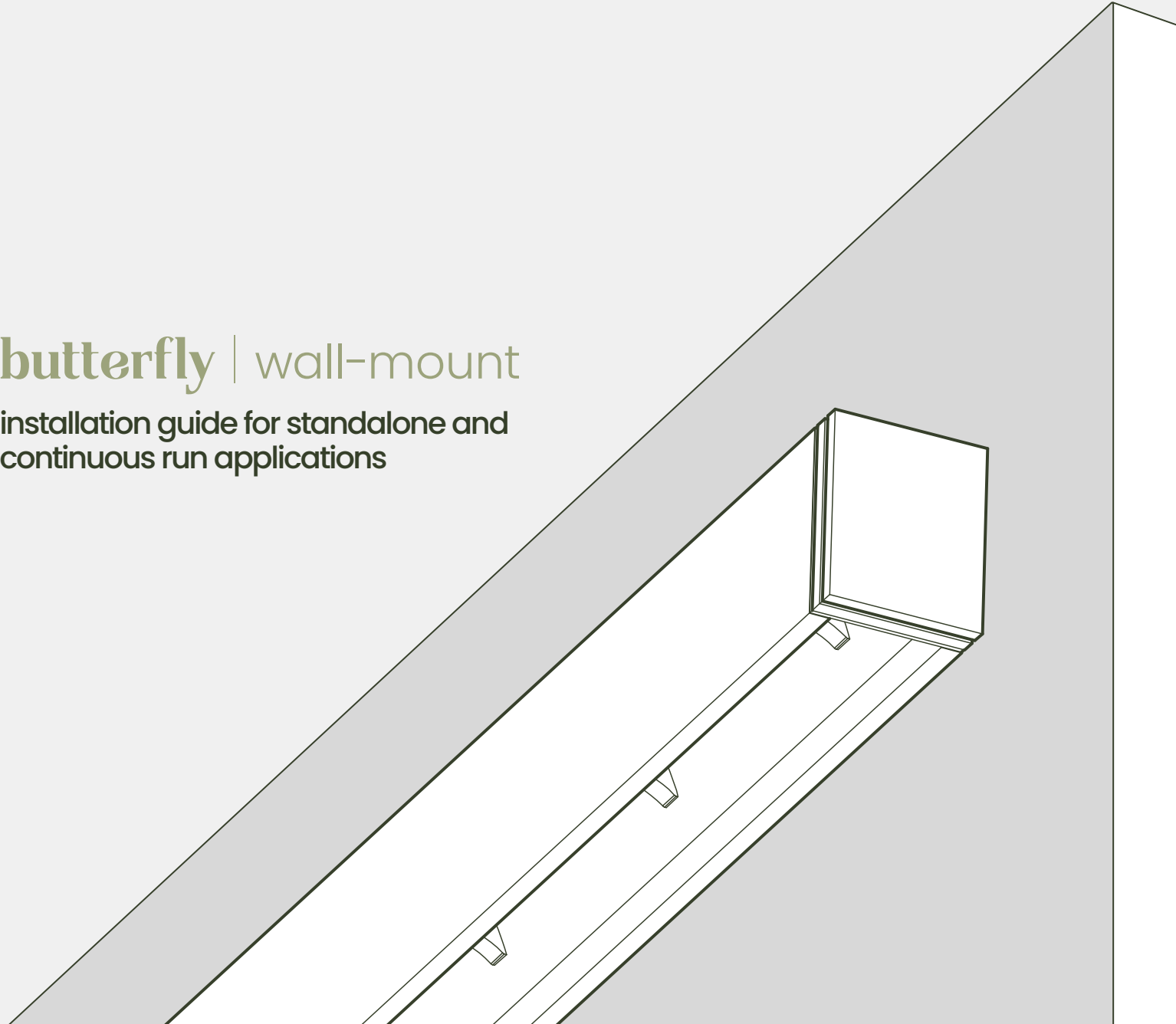

what's provided?

- Installation must be performed by a licensed electrician familiar with all local codes and relevant site requirements. Site conditions suitable for the specified product and adherence to code are the responsibility of installer.
- Follow the installation instructions provided. Failure to follow provided installation instructions could result in product damage or failure.
- Before installing, inspect luminaire, power wire, and suspension cordage for any damage that may have occurred during transport and unpacking. Do not install damaged product or components.
- To avoid electric shock always disconnect power when installing or servicing fixture.
- Wall conditions, support structure, and appropriate fasteners for wall substrate must be adequate for fixture weight and specifications.
- It is highly recommended to handle wood product with nitrile or other non-marring gloves.
- Clean wood surfaces only with dry cloth. Do not use water, solvents, or abrasive pads as they could permanently damage the natural wood finish.

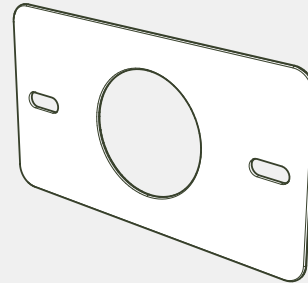

j-box cover

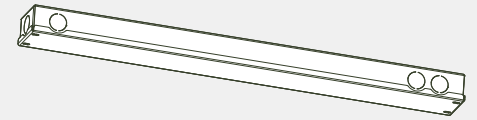

driver box w/ driver

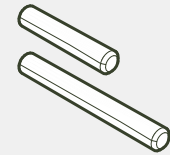

dowels (for continuous runs only)

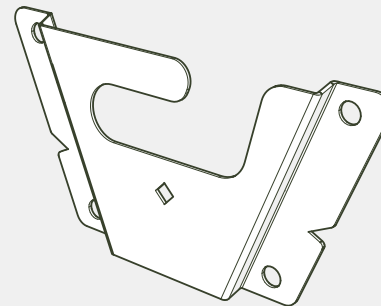

wall bracket

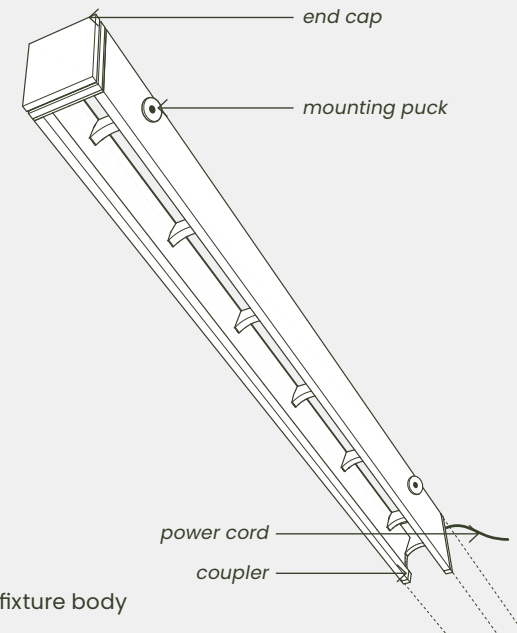

fixture body

1

Mark a horizontal centerline representing the center of the fixture body height:

Ensure that the line is level. Single gang junction boxes will need to be centered horizontally on the centerline and wall brackets will be aligned to the centerline as shown below. See step 2 for horizontal spacing.

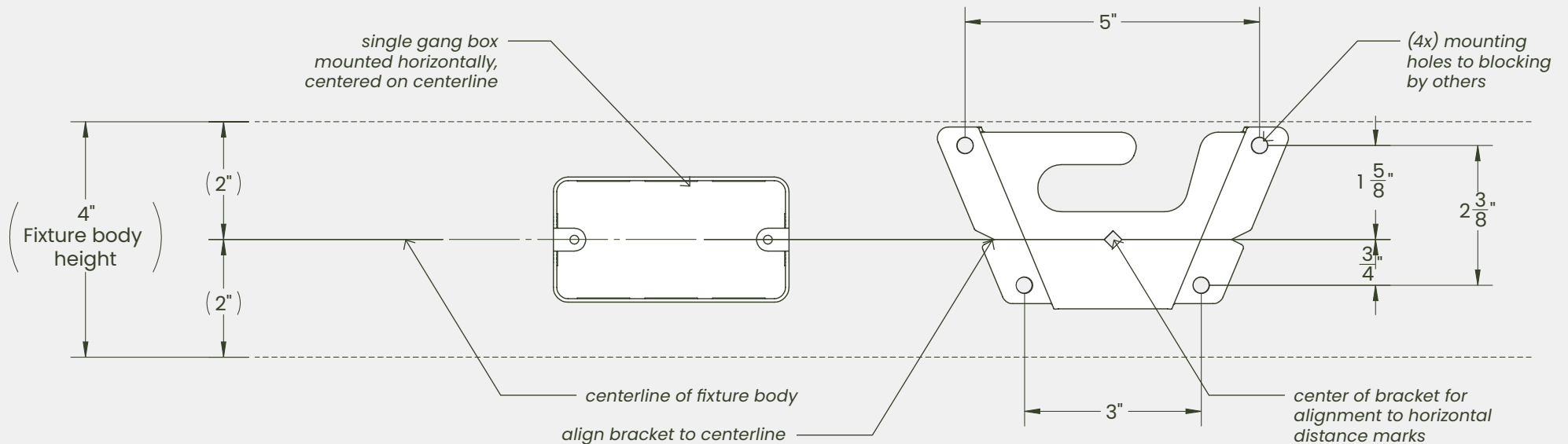

2

Locate junction boxes and wall brackets along centerline:

For a **standalone fixture**, there will be **(2)** brackets and **(1)** junction box.

For a **continuous run**, there will be **(2)** wall brackets and **(1)** junction box **per fixture section**.

The horizontal locations of the junction box and wall brackets are measured relative to the nominal (specified) length.

(Nominal lengths do not include the 7/8" end cap at each end.)

(Refer to approved submittal drawing for fixture or fixture section lengths if necessary)

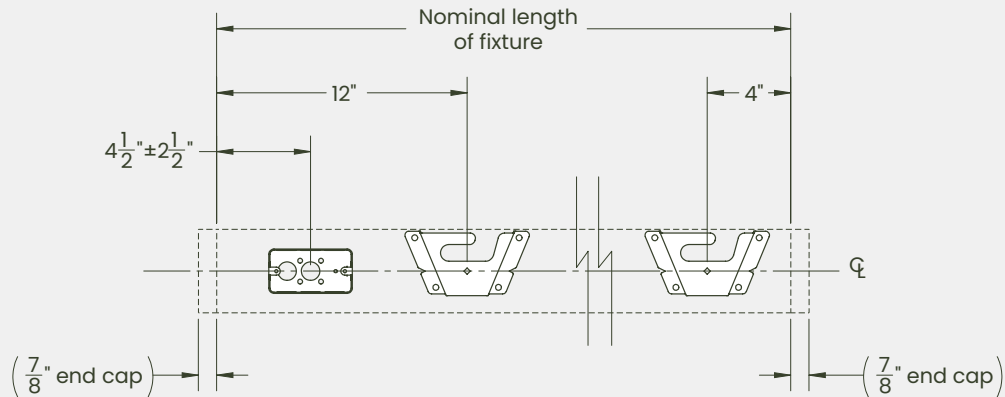

standalone fixture

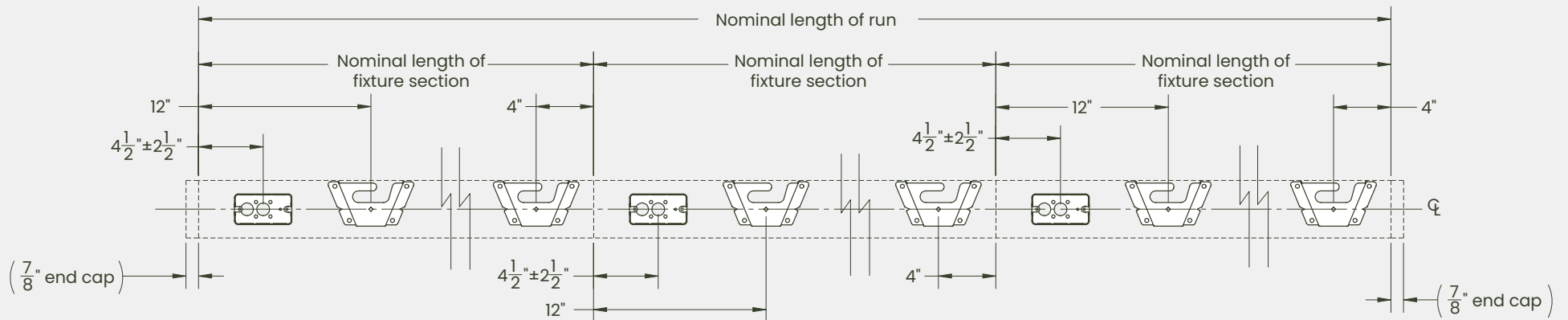

continuous run

3

Locate driver box(es) in a remote location:

See following page for further details regarding driver box mounting and size. Unless otherwise specified, (1) driver box per fixture section is required and must be mounted in a remote and serviceable location by others. Low voltage to be run by others from driver box to corresponding fixture section junction box.

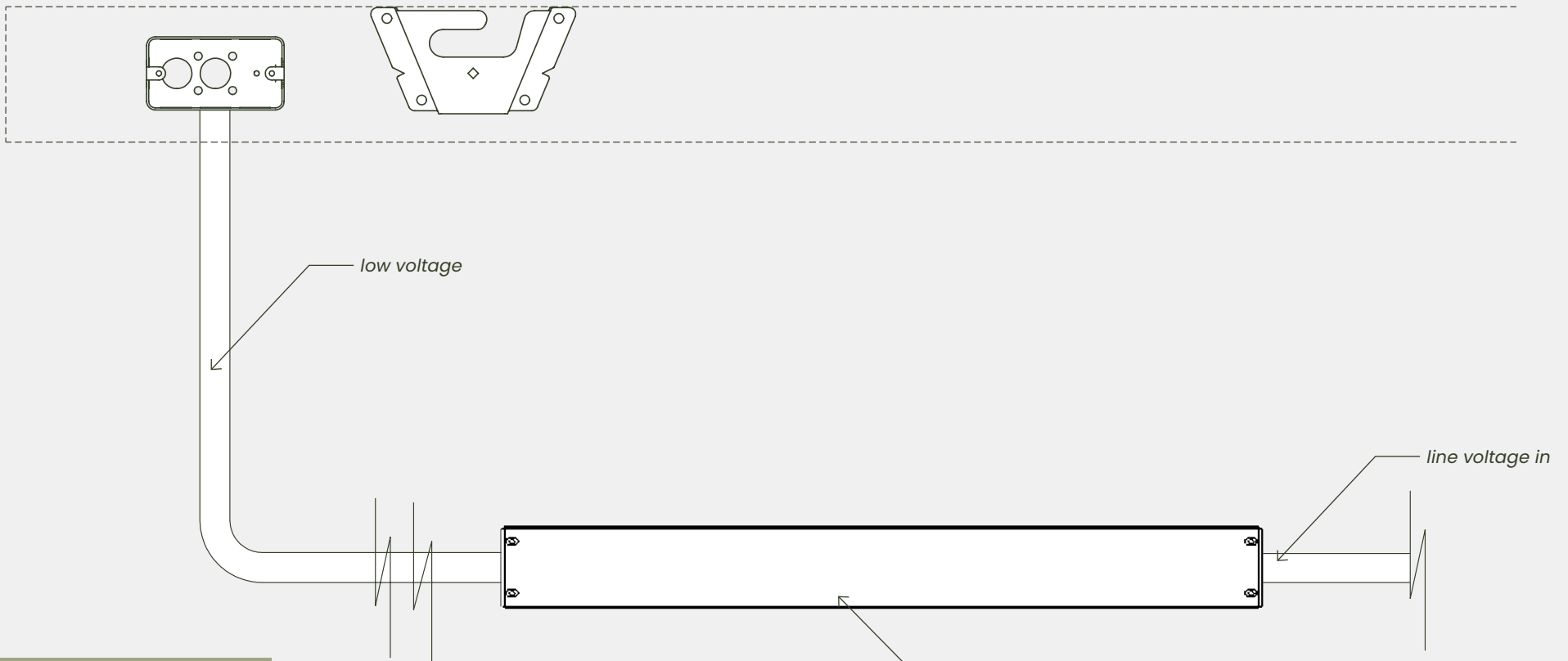

low voltage run max length	
22AWG	50'
18AWG	80'
16AWG	125'
14AWG	200'

driver box to be located remotely by others. 1 driver box per fixture section unless otherwise specified.

4

Driver box details:

Refer to wiring guides (pages 11-13) for wiring details.

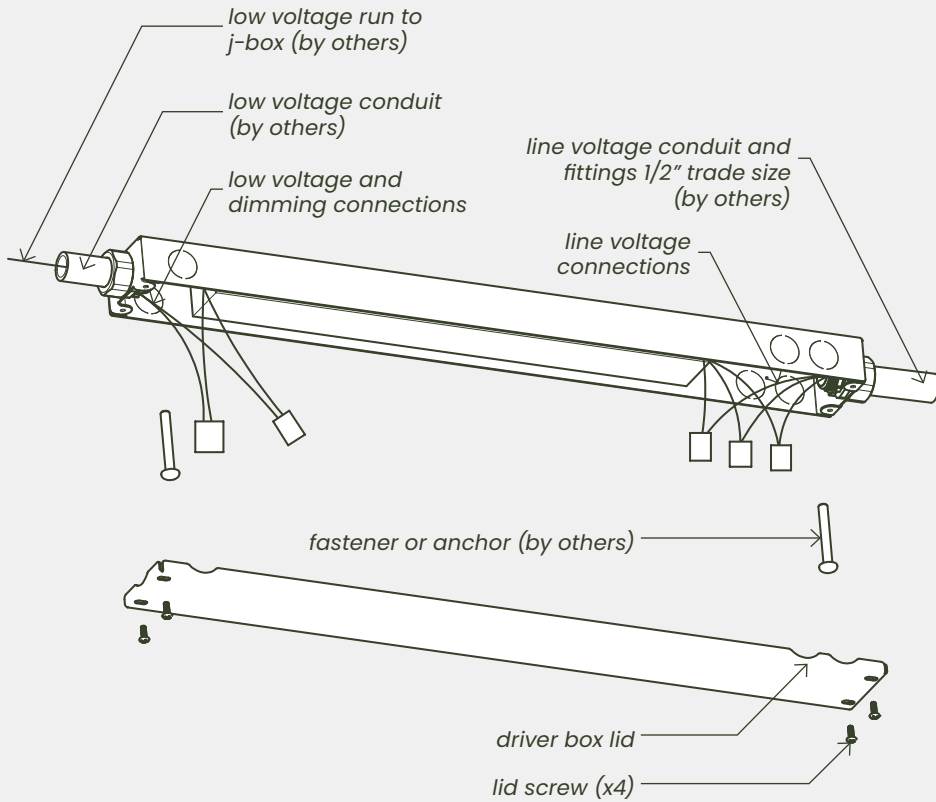

low voltage run max length	
22AWG	50'
18AWG	80'
16AWG	125'
14AWG	200'

a. 1 driver box (for static white)

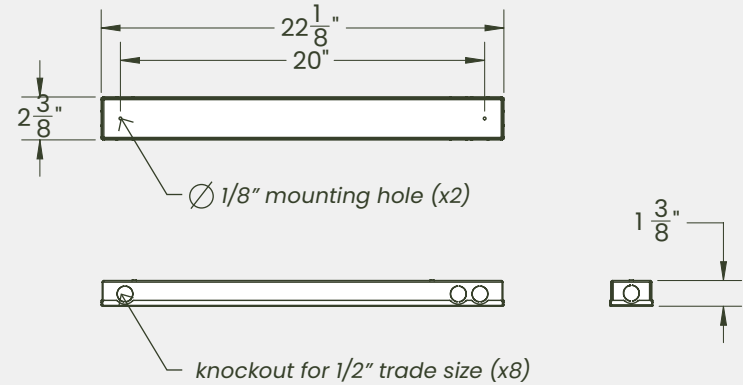

b. 2 driver box (for tunable white and custom applications)

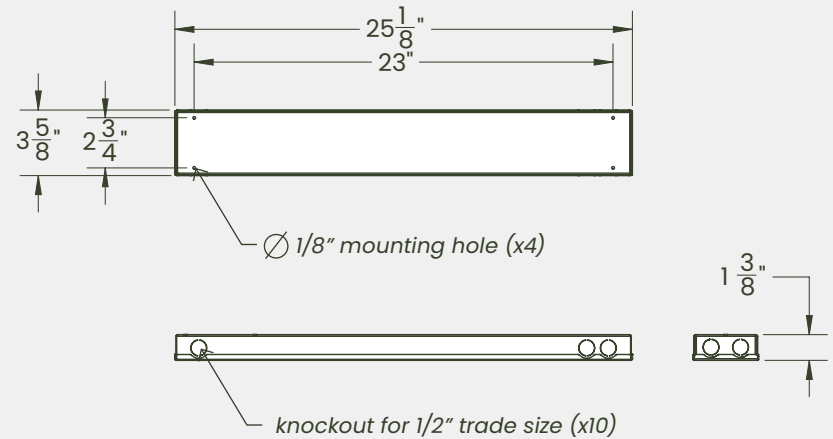

5

With junction boxes and wall brackets in place, attach first fixture section as per below:

In a continuous run, the first fixture section will always be the far left section. The sections of the run will be installed from left to right.

- a. Attach j-box cover to j-box (j-box screws by others).
Make low voltage connection and place splice into j-box.

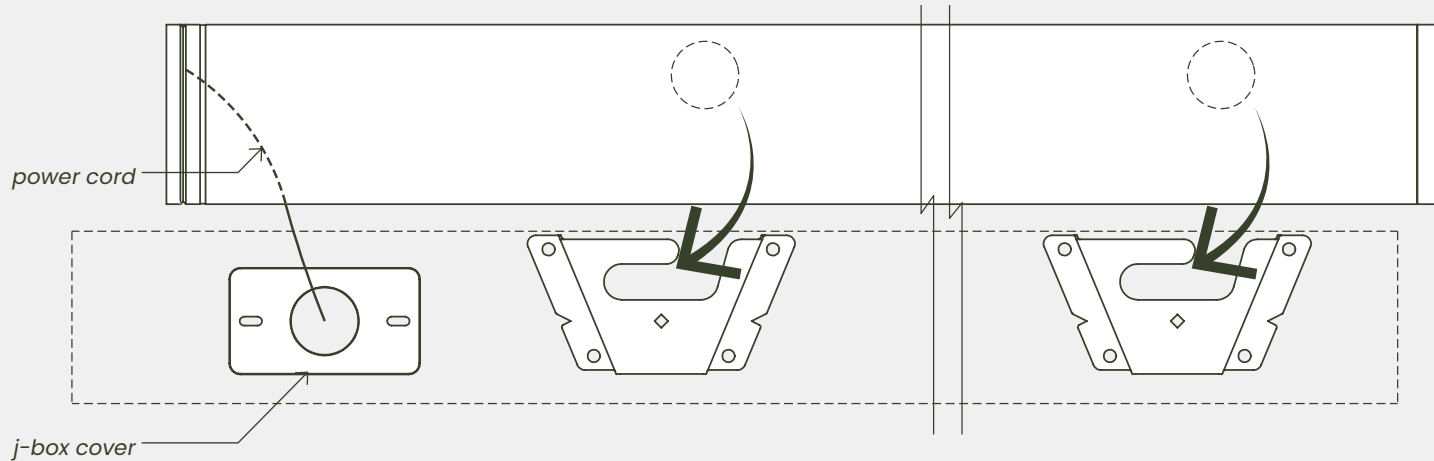

- b. Slide fixture body into place such that mounting puck engages wall bracket. Slide fixture body left into final position.

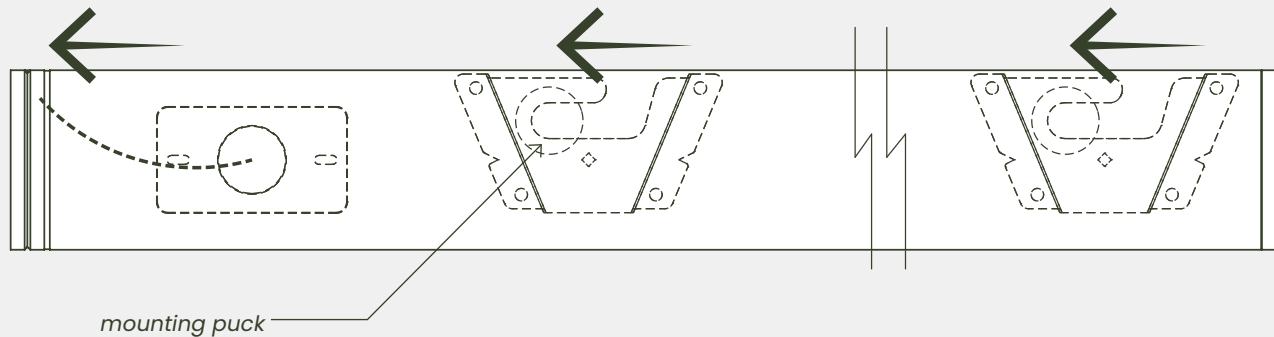

6a

Attach second fixture section: (Continuous runs only)

a. Insert 3x70mm dowel into previous fixture section as shown. Attach j-box cover to j-box.

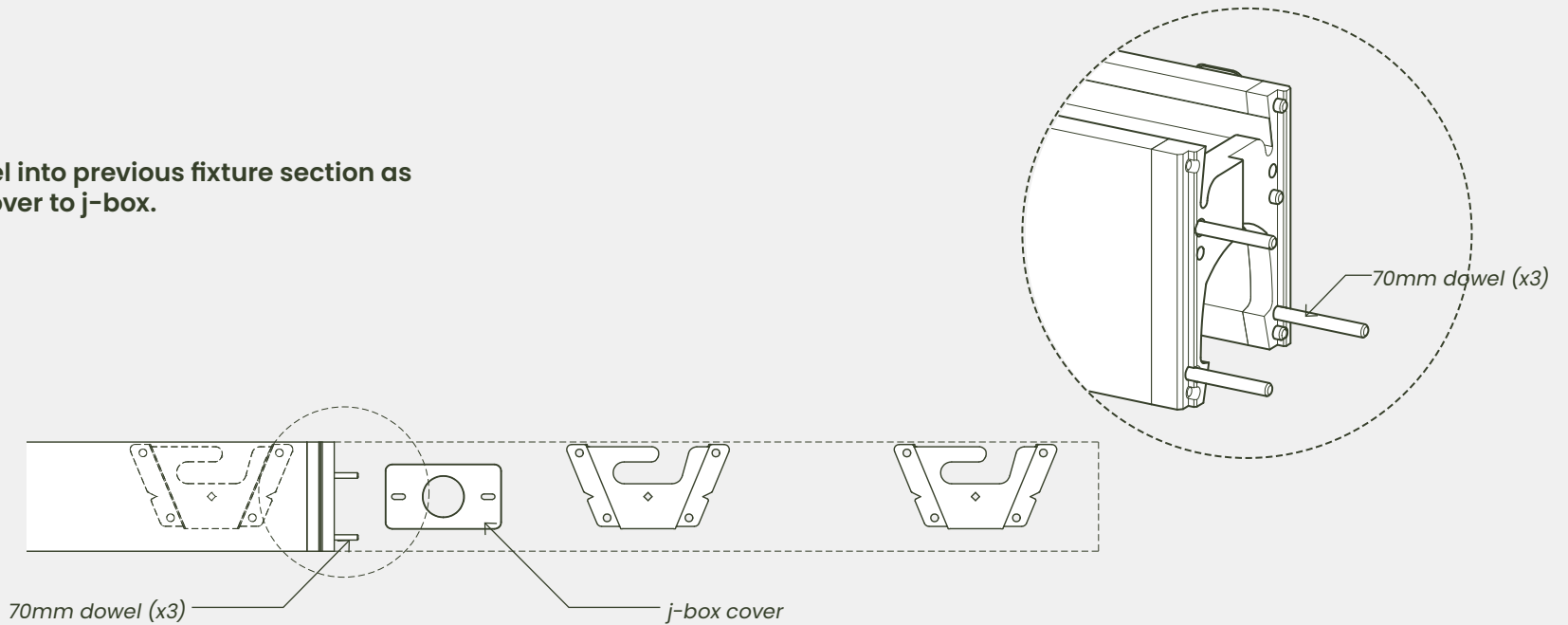

b. Make low voltage connection and place splice into j-box. Slide fixture section into position on the wall brackets.

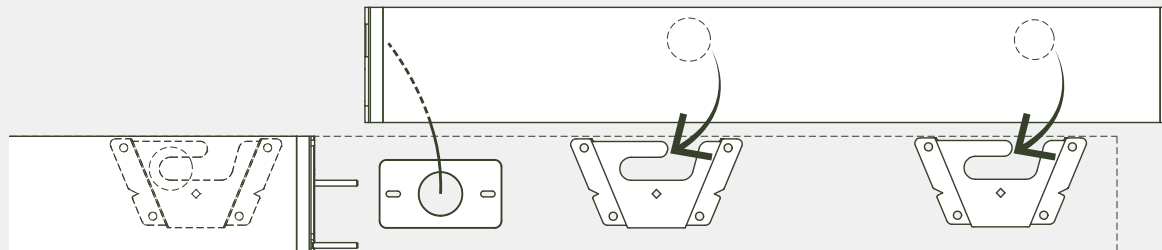

6b

Attach second fixture section; continued:
(Continuous runs only)

c. Slide the fixture section left such that the 2 sections are aligned via the dowels.

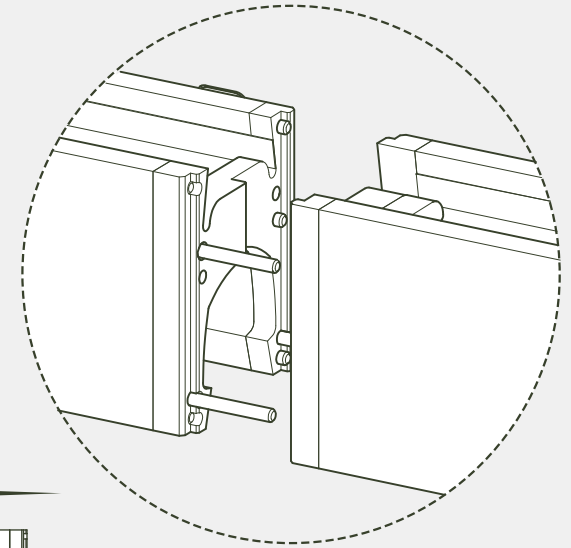
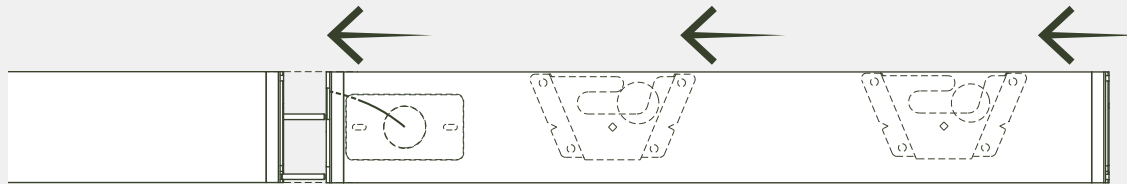

d. The 2 fixture sections are now install complete. The seam between the sections should be tight with no gapping.

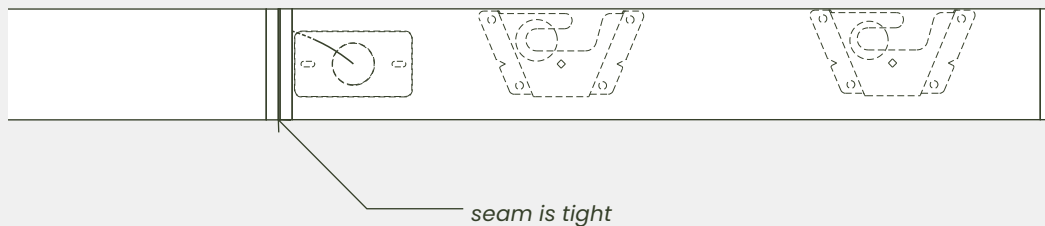

7

Repeat step 6 for additional sections of a continuous run. Installation complete.

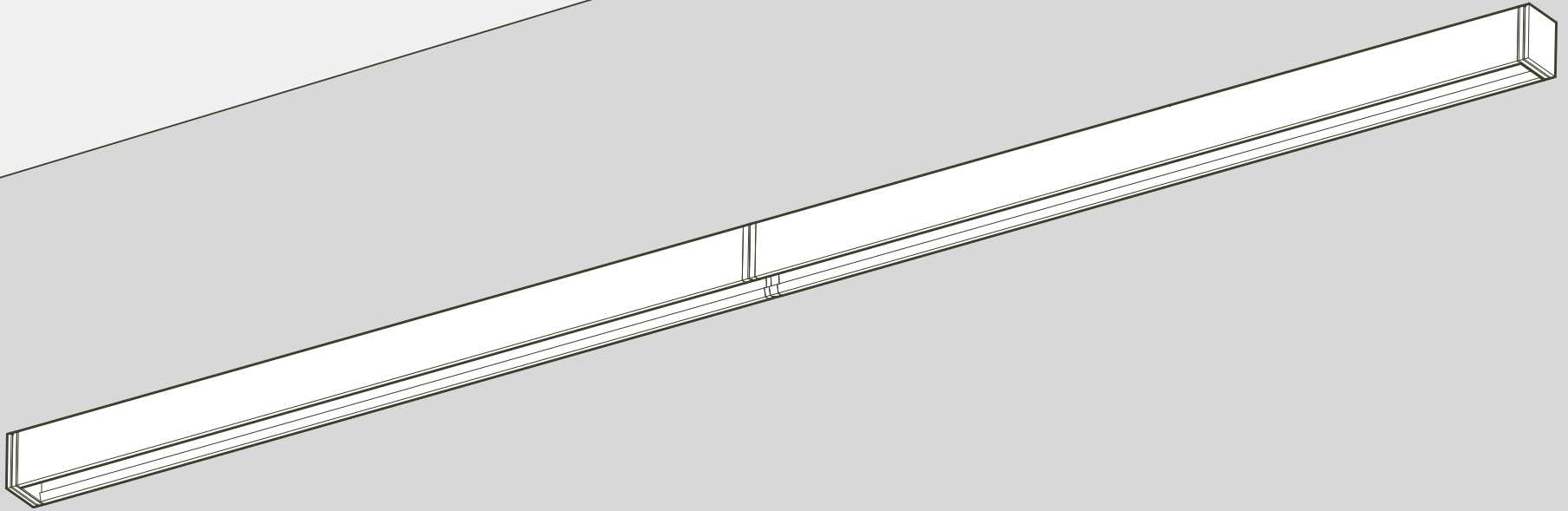

wiring guide

Do not connect lightly unit directly to line voltage. This will result in permanent damage and all warranty will be void.

static CCT
0-10V control

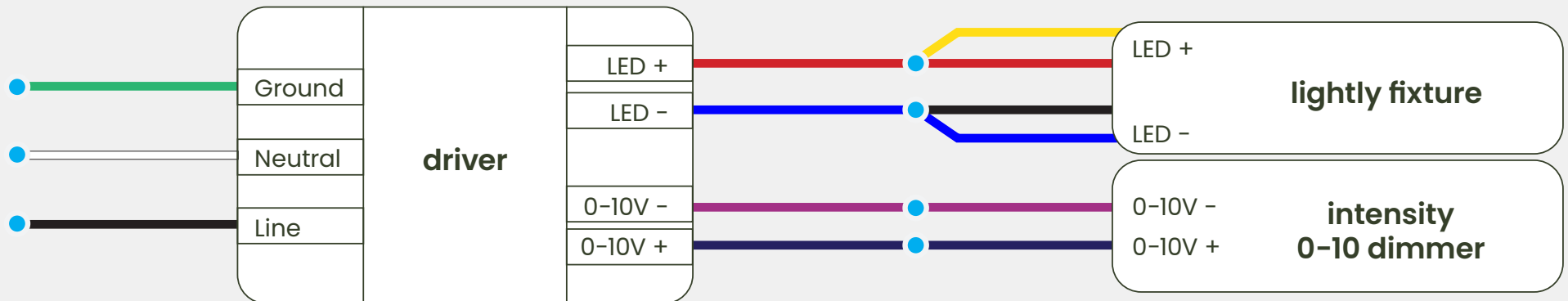

wiring guide

Do not connect lightly unit directly to line voltage. This will result in permanent damage and all warranty will be void.

tunable white
0-10V control

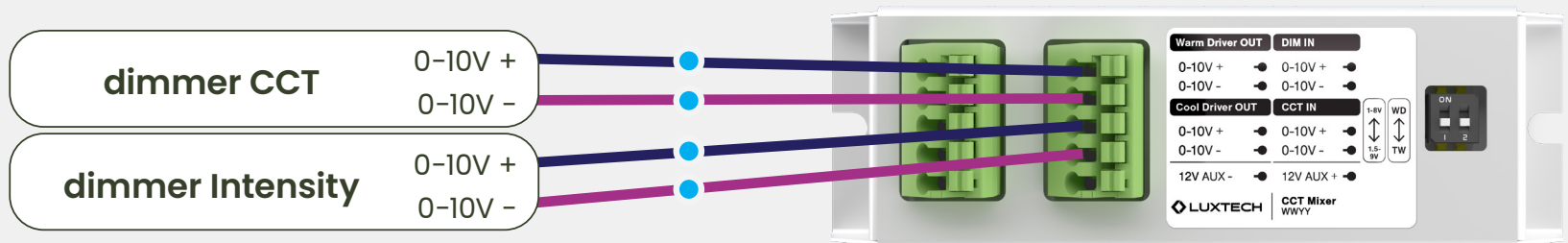
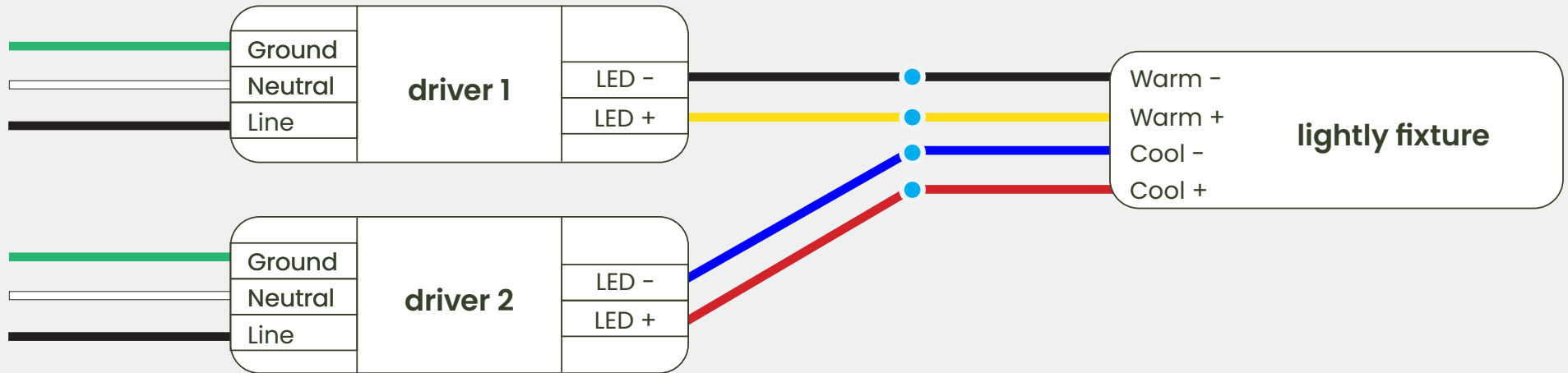

Note: CCT Mixer Device is installed by Lightly and pre-wired to the LED Drivers. Only the wire connections required to be made by EC are displayed.